

BUREAU OF FIRE PROTECTION OFFICE

Office

FIRE SAFETY EVALUATION CLEARANCE (FSEC) FOR CONSTRUCTION OF NEW BUILDING/REPAIR/RENOVATION/MODIFICATION/ALTERA TION/ADDITIONAL/CHANGE OF TYPE OF OCCUPANCY OF BUILDINGS STRUCTURE OF FACILITY OR PORTION THEREOF

Frontline Service

❖ CLIENTS:

Any person or entity (private individual, investor, businessman.

❖ REQUIREMENTS:

1. Endorsement from the Local Building Official
2. Three (3) sets of Building Plans and Specifications
3. One (1) set of Bills of Materials and Cost Estimate
4. Three (3) sets of detailed Fire Safety Plans and Specification or Fire and Safety Assessment Report (FALAR) – Part 1 for Occupancy of at least 50 persons.

❖ SCHEDULE OF ACTIVITY:

Monday to Friday, 8:00 a.m. to 5:00 p.m.

❖ FEES:

One tenth of one percentum of estimated value of buildings or structures to be erected/repared/ renovated/modified but not to exceed fifty thousand (P 50,000.00) pesos.

BUREAU OF FIRE PROTECTION OFFICE

Office

FIRE SAFETY INSPECTION CERTIFICATE (FSIC) FOR OCCUPANCY/BUSINESS PERMIT

Frontline Service

❖ CLIENTS:

All business owners/building owners (except single family dwellings), investors.

❖ REQUIREMENTS:

1. Endorsement from the Building Official (BOI), Business Permit Licensing (BPLO)
2. Photocopy of Building Permit and Assessment of Occupancy Permit Fee/Assessment of Business Permit Fee, BPLO Assessment, Tax Bill for Business Permit as the case maybe
3. Copy of Fire Insurance Policy (if any)
4. Copy of latest Fire Safety Inspection Certificate immediately preceding this application (if any)
5. Three (3) sets of Fire and Life Safety Assessment Report – (Fallar 2) for Occupancy Permit or Fallas for Business Permit (for Occupancy or at least 50 persons)

❖ SCHEDULE OF ACTIVITY:

Monday to Friday, 8:00 a.m. to 5:00 p.m.

❖ FEES:

Ten (10%) percent of all fees charged by the Building Official or by the Local Government Unit or by other Government Agencies concerned in granting pertinent permits or licenses.

BFP FLOWCHART OF FIRE SAFETY EVALUATION CLEARANCE (FSEC)

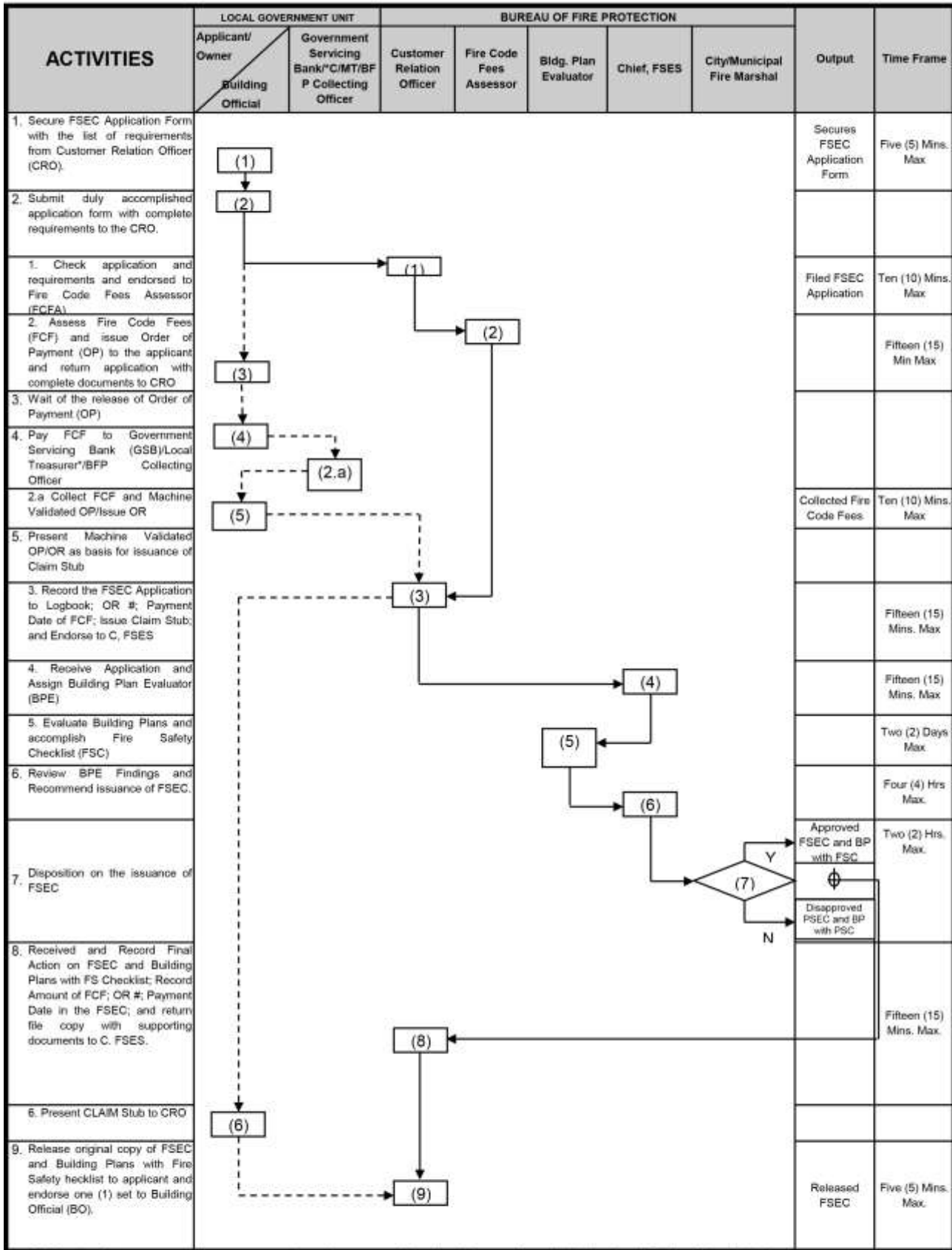

*Subject to change as soon as memorandum of agreement for e-banking are forged with the Land Bank of the Philippines (Government Servicing Bank) and/or nearest Rural Bank.

Maximum of Three (3) Days from Filing/Acceptance of FSEC Application

LEGEND:
 → Activity for Client
 → Activity for BFP

BFP - Bureau of Fire Protection, **BO** - Building Official, **BP** - Building Plans, **BPE** - BuildingPlan Evaluator, **C/MFM** - City/Municipal Fire Marshal, **CRO** - Customer Relation Officer, **FSC** - Fire Safety Checklist, **FSEC** - Fire Safety Evaluation Clearance, **FCF**- Fire Code Fees, **FCFA** - Fire Code Fees Assessor, **C**, **FSES** - Chief Fire Safety Enforcement Section, **GSB** - Government Servicing Bank, **LGU** - Local Government Unit, **OP** - Order of Payment, **OR** - Official Receipt